



# BUILDING ANALYSTS



"Good news Sir, I found the roof leak"

# WHY SOME FLAT ROOFS LEAK

There are common problems in the construction of flat roofs.

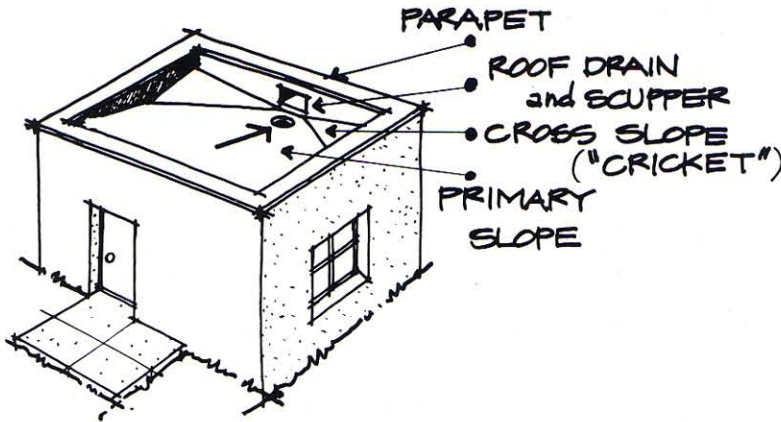

## 1 Insufficient Roof Slope and Lack of Drainage

- The Uniform Building Code (UBC), 1988 Edition, requires roof systems to be sloped a **minimum** of 1/4 inch in 12 inches for positive drainage.
- Most manufacturer warranties require roofs to be free of ponding water 48 hours after a rainfall (consult individual manufacturer's specific requirements).
- Where water cannot drain over the roof edge, the UBC requires a roof drain and an overflow drain at every low point of the roof.
- Scuppers, or openings through the wall, can be used in lieu of overflow drains. The UBC requires that overflow scuppers be three times the size of the roof drain and have an inlet line located a maximum of 2 inches above the adjacent low roof point.

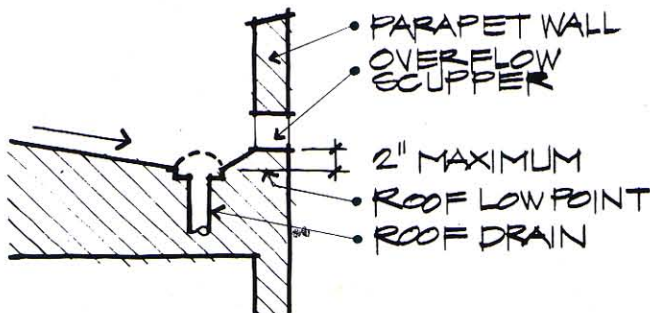

## 2 Omission of Cant Strips

Some roofing materials are too brittle to make the 90° turn up the wall from the roof deck. Cant strips allow for the continuous transition of roofing materials without splitting or tearing that would permit water into the structure.

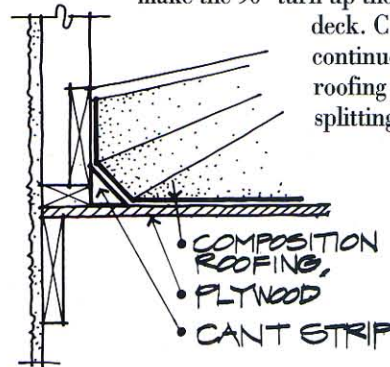

## 3 Lack of Proper Coping

- A properly sloped sheet metal coping at the top of parapet walls will reduce the potential for water intrusion and eliminate most staining from top-of-wall run-off.
- Stucco-capped parapet walls require a higher level of care in design and construction. Stucco does not prevent water intrusion, so the top of the wall should be waterproofed as if it were a roof.

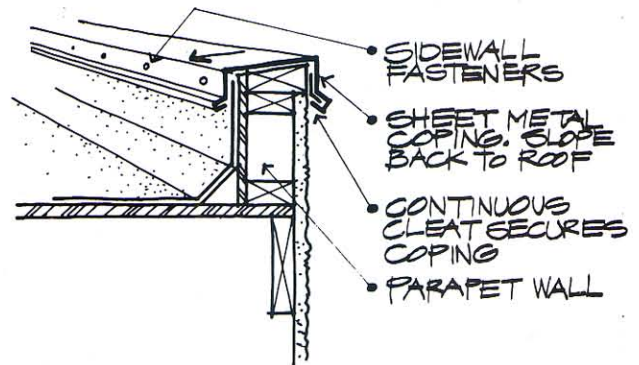

Building Analysts is a full-service architectural and engineering firm with many years of experience in construction litigation. Our services include: architectural and structural investigations, repair recommendations, preparation of exhibits and expert testimony. We hope this newsletter is helpful. Please contact Stan Livingston, Pete diGirolo, Mike Romanowski or Bob Carroll at Building Analysts if you need our input or recommendation. (619) 234-8153

Building Analysts' newsletter is intended to provide general information for those involved in construction litigation. The topics contained in this publication are abbreviated and applicability to a particular situation may vary according to circumstances. Since design and construction technologies change over time, the information contained herein may become outdated. Building Analysts recommends you contact the appropriate design professional for specific information regarding individual projects.

FALL 1992 NEXT ISSUE: BELOW-GRADE WATERPROOFING